

# Deformation and Displacement of Vacuum System for One Unit Cell in the SPring-8 Storage Ring

Hiroshi Saeki, Kowashi Watanabe, Hiroyuki A. Sakaue, Haruo Ohkuma, Motoaki Iizuka, Seiichi Sato, and Suck Hee Be

SPring-8, Kamigori, Ako-gun, Hyogo 678-12, Japan

## 1. Introduction

The assembly test of the SPring-8 storage ring vacuum system of one unit cell was carried out. We had made some vacuum test for the one unit cell. In this report, the measurement's results of the deformation and displacement of vacuum chambers are described. The other vacuum test will be reported in this issue of the SPring-8 Annual Report by H. Ohkuma et al.

## 2. Measurements and results

Since the button pickup electrodes of beam position monitors (BPM's) are directly welded to extruded aluminum alloy chambers, the chamber deformation is one of the factors which limits the accuracy of the position measurement of the stored beam. Therefore the deformation of straight section chamber (SSC) with BPM's due to the evacuation were measured using dial indicators which have a minimum resolution of  $1\ \mu\text{m}$ . Dial indicators were attached with magnetic base to magnet yoke of quadrupole and/or sextupole magnets as fixed reference points. After recording measured values as reference points, vacuum chambers were evacuated from an atmospheric pressure using roughing pumping systems which consists of a turbo molecular pump and a rotary pump. To suppress the effects of the chamber deformation at the BPM section, two reinforced blocks are mounted just beside the BPM in the SSC. A reinforced block of the SSC in the upper stream was fixed to a magnet girder. The SSC in the down stream could be supported by a leaf-spring device or by a simple vertical support, making it possible to accommodate thermal expansion of the chamber in the longitudinal direction during bakeout cycle. The details of support device and structure for each chamber are described in Ref.1. The measurements of the chamber

deformation due to the evacuation was done in the one of three SSC's in the one unit cell, which is called SS1C. Figure 1 shows the variation of the reinforced block for the BPM at the SS1C. The chamber wall near the reinforced block made deformation of  $-7\ \mu\text{m}$  and  $-24\ \mu\text{m}$  at A and B as shown in Fig.1, respectively. The chamber deformation at the BPM section due to evacuation of the SSC was less than  $30\ \mu\text{m}$  required for BPM.

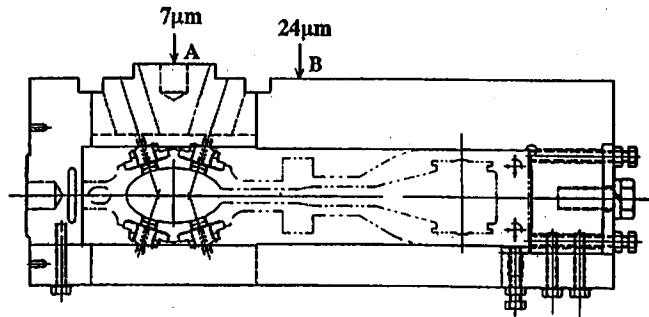

Fig.1. Measurement's results of the deformation of the BPM section due to the evacuation of the SSC.

The chamber displacement over the one unit cell due to the evacuation were also measured using same method. Figure 2 shows variation of each measuring point for the one unit cell at the reached pressure of  $2.0 \times 10^{-4}\text{Pa}$ . As the result, vacuum chambers connected with large-sized bellows were pulled largely in the longitudinal (Z) direction and the sucking force also made large displacement of the chambers in the horizontal (X) and vertical (Y) direction.

The chamber displacement due to the bakeout were also measured using dial indicators. Figure 3 shows the position reproducibility of the chambers before and after bakeout at the temperature of  $150\ \text{C}$ . The position reproducibility at the BPM section due to

bakeout was larger than 50  $\mu\text{m}$  required for the BPM and at a few locations range from 100 to 150  $\mu\text{m}$  because of the weakness of the rigid support and magnet girder. From the results, in order to be able to resist the sucking force (600 - 700 kgf) by the large-sized bellows, it is necessary to improve the strength of the support devices and structures, especially for the SSC's with the BPM's and for crotches with absorber.

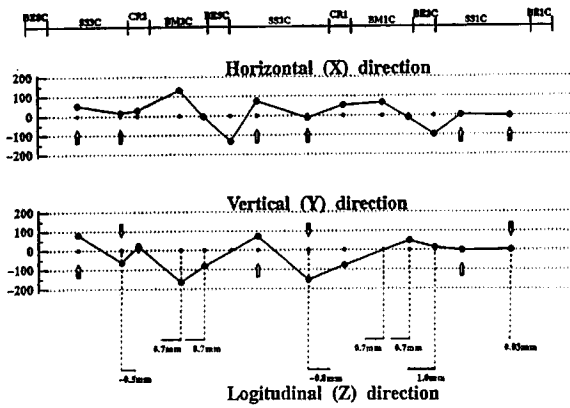

Fig.2. The displacement of the chambers over the one unit cell due to evacuation. The arrows

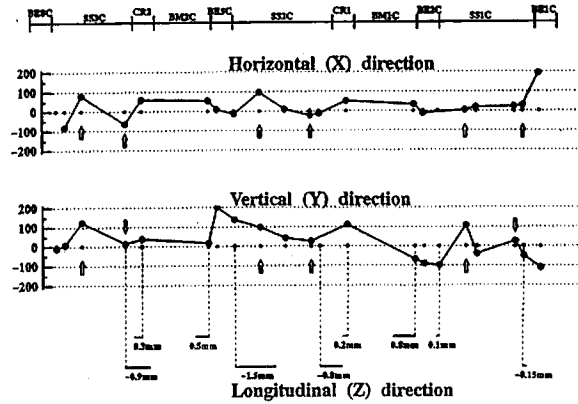

Fig.3. Position reproducibility of the chamber before and after bakeout. The arrows indicate the