

The data to be read in conjunction with the Hydrogen Thyatron Preamble.

ABRIDGED DATA

Deuterium-filled tetrode thyatron with ceramic/metal envelope, featuring low jitter, firing time and drift. Suitable for switching high power at high pulse repetition rates or for switching long pulses. A reservoir operating from a separate heater supply is incorporated.

Peak forward anode voltage 40 kV max
 Peak anode current (see Ratings) 6.0 kA max
 Average anode current 4.0 A max

GENERAL

Electrical

Cathode (connected internally to one end of heater) oxide coated
 Cathode heater voltage 6.3 ^{+ 0.3} _{- 0.0} V
 Cathode heater current 40 A
 Reservoir heater voltage (see note 1) 5.0 V
 Reservoir heater current 10 A
 Tube heating time (minimum) 15 min
 Anode to grid 2 capacitance 40 pF

Mechanical

Seated height 212.7 mm (8.375 inches) max
 Clearance required below mounting flange 57.15 mm (2.250 inches) min
 Overall diameter (mounting flange) 152.4 mm (6.000 inches) nom
 Net weight 3.5 kg (7³/₄ pounds) approx
 Mounting position (see note 2) any
 Tube connections see outline

Cooling

liquid or forced-air
 Liquid oil or coolant immersion
 Forced-air see below
 Cooling by oil or coolant immersion is preferred in view of the high voltages present. Further information is contained in the relevant section of the Preamble.

The tube may be cooled by forced-air directed mainly onto the base, and the metal/ceramic envelope should be maintained below the maximum rated temperature. An air flow of at least 2.83 m³/min (100 ft³/min), depending on the mechanical layout, will be necessary to keep the tube operating temperatures under the limits specified below.



In addition to 300 W of heater power, the tube dissipates from 100 W per ampere average anode current, rising to 300 W/A at the highest rates of rise and fall of anode current.

The cathode end of the tube must be cooled whenever heater voltages are applied, since the cathode flange will reach a temperature of 120 °C above ambient in the absence of cooling.

Envelope temperature:
 ceramic, anode and grid 150 °C max
 cathode flange and base 120 °C max

MAXIMUM AND MINIMUM RATINGS

These ratings cannot necessarily be used simultaneously, and no individual rating must be exceeded.

	Min	Typical	Max	
Anode (Pulse Modulator Service)				
Peak forward anode voltage (see note 3)	-	-	40	kV
Peak inverse anode voltage (see note 4)	-	-	35	kV
Peak anode current	-	6.0	-	kA
Peak anode current (pulse repetition rate limited to 60 pps max)	-	-	8.0	kA
Average anode current	-	-	4.0	A
Rate of rise of anode current (see notes 5 and 6)	-	10	-	kA/ μ s
Pulse repetition rate (see note 7)	-	400	-	pps

	Min	Max	
Anode (Single Shot, see note 8)			
DC forward anode voltage	-	30	kV
Peak anode current	-	40	kA
Rate of rise of anode current	-	-	see note 5
Total conducted charge:			
capacitor discharge	-	0.4	C
power supply follow-on	-	18	C
Repetition frequency	1 pulse per 10 s	-	max

Grid 2

Unloaded grid 2 drive pulse voltage (see note 9)	500	2000	V
Grid 2 pulse duration	0.5	-	μ s
Rate of rise of grid 2 pulse (see note 6)	10	-	kV/ μ s
Grid 2 pulse delay	0.5	3.0	μ s
Peak inverse grid 2 voltage	-	450	V
Loaded grid 2 bias voltage	-50	-180	V
Forward impedance of grid 2 drive circuit	50	500	Ω

Grid 1 - Pulsed

Unloaded grid 1 drive pulse voltage (see note 9)	400	1000	V
Grid 1 pulse duration	2.0	-	μ s
Rate of rise of grid 1 pulse (see note 6)	1.0	-	kV/ μ s
Peak inverse grid 1 voltage	-	450	V
Loaded grid 1 bias voltage	-	-	see note 10
Peak grid 1 drive current	0.5	1.5	A

Grid 1 - DC Primed (See note 11)

DC grid 1 unloaded priming voltage	75	150	V
DC grid 1 priming current	75	150	mA

Cathode

Heater voltage	6.3	+ 0.3 - 0.0	V
Heating time	15	-	min

Reservoir

Heater voltage (see note 1)	4.5	6.5	V
Heating time	15	-	min

Environmental

Ambient temperature	-50	+90	$^{\circ}$ C
Altitude	-	3	km
	-	10 000	ft

CHARACTERISTICS

	Min	Typical	Max	
Critical DC anode voltage for conduction (see note 12)				
	-	0.5	1.0	kV
Anode delay time (see notes 12 and 13)				
	-	0.1	0.25	μ s
Anode delay time drift (see notes 12 and 14)				
	-	15	50	ns
Time jitter (see note 12)				
	-	1.0	5.0	ns
Recovery time (see note 7)				
	-	-	-	see note 7
Cathode heater current (at 6.3 V)				
	35	40	45	A
Reservoir heater current (at 5.0 V)				
	8.0	10	12	A

NOTES

- The reservoir heater must be decoupled with a suitable capacitor to avoid damage by spike voltages. The recommended reservoir heater voltage for each individual tube is stamped on the tube envelope. This recommended value is determined for hold-off at the maximum anode voltage under DC conditions. For lower voltages and modulator operation the reservoir heater voltage should be increased to a value consistent with voltage hold-off at the operating level. Maximum reservoir voltage (i.e. maximum gas pressure in the tube) is one prerequisite for maximum thyratron life. The reservoir voltage should be stabilised to ± 0.05 V.
- The tube must be mounted by means of its mounting flange.
- Under resonant charging conditions a maximum anode voltage of 35 kV is recommended. Using command charging techniques, where the voltage appears at the anode for only a short time (< 1 ms), this thyratron may be operated at up to 40 kV.
- The peak inverse voltage including spike must not exceed 10 kV for the first 25 μ s after the anode pulse. Amplitude and rate of rise of inverse voltage contribute greatly to tube dissipation and electrode damage; if these are not minimised in the circuit, tube life will be shortened considerably. The aim should be for an inverse voltage of 3 - 5 kV peak with a rise time of 0.5 μ s.
- For single shot or burst mode applications this parameter can exceed 150 kA/ μ s. The ultimate value which can be attained depends to a large extent upon the external circuit.
- This rate of rise refers to that part of the leading edge of the pulse between 25% and 75% of the pulse amplitude.
- This thyratron has a long recovery time (50 - 100 μ s). The amount of time available for thyratron recovery must be maximised by circuit design, and reliable operation may necessitate the use of command charging techniques. The amount of time required for recovery is affected by gas pressure, peak current, pulse duration and load mismatch which keeps the thyratron in a conducting state.

8. Under fault conditions most of the coulombs are often in the power supply follow-on current, rather than the storage capacitor discharge.
9. Measured with respect to cathode. Pre-pulsing of grid 1 is recommended for modulator and high rate of rise applications. The last 0.25 μs of the top of the grid 1 pulse must overlap the corresponding first 0.25 μs of the top of the delayed grid 2 pulse.
10. DC negative bias voltages must not be applied to grid 1. When grid 1 is pulse driven, the potential of grid 1 may vary between -10 and $+5$ V with respect to cathode potential during the period between the completion of recovery and the commencement of the succeeding grid pulse.
11. When DC priming is used on grid 1, a negative bias of 100 to 180 V must be applied to grid 2 to ensure anode voltage hold-off. Also the higher grid 1 is pulsed, the larger the grid 2 negative bias must be to prevent the tube firing on the grid 1 pulse.
12. Typical figures are obtained on test using conditions of minimum grid drive. Improved performance can be expected by increasing grid drive.
13. The time interval between the instant at which the rising unloaded grid 2 pulse reaches 25% of its pulse amplitude and the instant when anode conduction takes places.
14. The drift in delay time over a period from 10 seconds to 10 minutes after reaching full voltage.

SCHEMATIC DIAGRAM

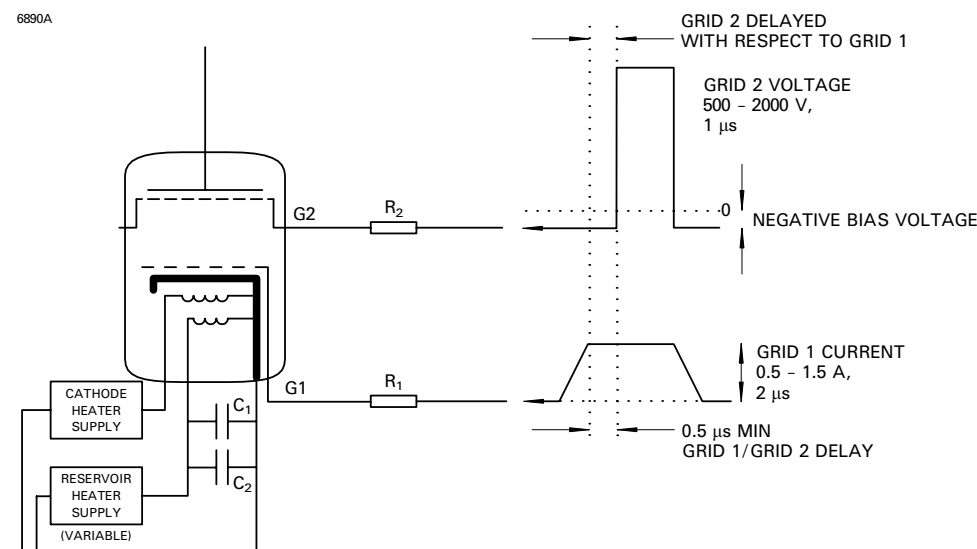

RECOMMENDED GRID, CATHODE AND RESERVOIR HEATER CONNECTIONS

- R_1 = Grid 1 series resistor. 12 W vitreous enamelled wirewound is recommended, of a total impedance to match the grid 1 drive pulse circuit.
- R_2 = Grid 2 series resistor. 12 W vitreous enamelled wirewound is recommended, of an impedance to match the grid 2 drive pulse circuit.
- C_1, C_2 = reservoir protection capacitors with a voltage rating ≥ 500 V;
- C_1 = 1000 pF low inductance (e.g. ceramic),
- C_2 = 1 μF (e.g. polycarbonate or polypropylene).

Components R_1 , R_2 , C_1 and C_2 should be mounted as close to the tube as possible.

OUTLINE

(All dimensions without limits are nominal)

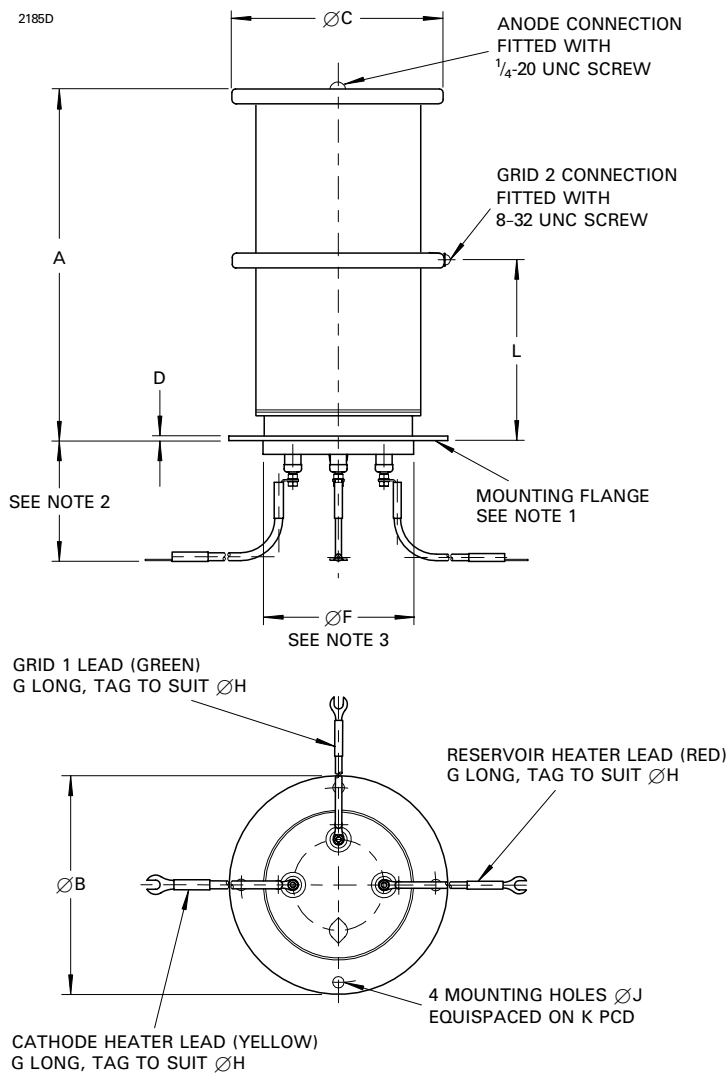

Ref	Millimetres	Inches
A	212.7 max	8.375 max
B	152.4	6.000
C	147.0	5.787
D	3.18	0.125
F	106.3 max	4.187 max
G	177.8 min	7.000 min
H	6.35	0.250
J	8.0	0.315
K	135.7	5.344
L	117.35	4.620

Inch dimensions have been derived from millimetres.

Outline Notes

1. The mounting flange is the connection for the cathode, cathode heater return and reservoir heater return.
2. A minimum clearance of 57.15 mm (2.250 inches) must be allowed below the mounting flange.
3. The recommended mounting hole is 108 mm (4.250 inches) diameter.

HEALTH AND SAFETY HAZARDS

Marconi Applied Technologies hydrogen thyratrons are safe to handle and operate, provided that the relevant precautions stated herein are observed. Marconi Applied Technologies does not accept responsibility for damage or injury resulting from the use of electronic devices it produces. Equipment manufacturers and users must ensure that adequate precautions are taken. Appropriate warning labels and notices must be provided on equipments incorporating Marconi Applied Technologies devices and in operating manuals.

High Voltage

Equipment must be designed so that personnel cannot come into contact with high voltage circuits. All high voltage circuits and terminals must be enclosed and fail-safe interlock switches

must be fitted to disconnect the primary power supply and discharge all high voltage capacitors and other stored charges before allowing access. Interlock switches must not be bypassed to allow operation with access doors open.

X-Ray Radiation

All high voltage devices produce X-rays during operation and may require shielding. The X-ray radiation from hydrogen thyratrons is usually reduced to a safe level by enclosing the equipment or shielding the thyratron with at least 1.6 mm (1/16 inch) thick steel panels.

Users and equipment manufacturers must check the radiation level under their maximum operating conditions.

Whilst Marconi Applied Technologies has taken care to ensure the accuracy of the information contained herein it accepts no responsibility for the consequences of any use thereof and also reserves the right to change the specification of goods without notice. Marconi Applied Technologies accepts no liability beyond that set out in its standard conditions of sale in respect of infringement of third party patents arising from the use of tubes or other devices in accordance with information contained herein.